

Hydraulic Inline and 90° Live Swivels Seal Rebuilding Kit Instructions

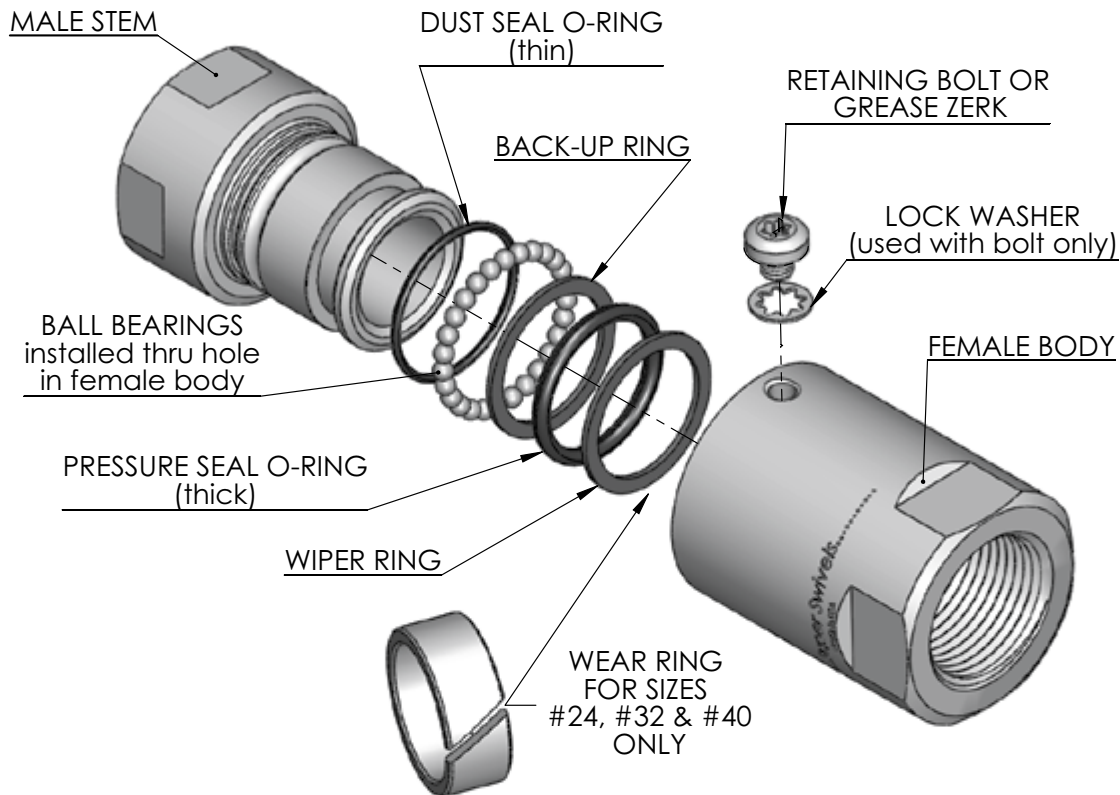

1. Remove retaining bolt or grease zerk (some models have a permanent grease zerk).
2. Wash swivel in solvent and rotate while immersed to remove grease from the ball bearing groove.
3. Remove ball bearings by rotating swivel with ball loading hole pointed downward. If remaining grease in ball groove prevents balls from falling free when centered over loading hole, tap swivel on work bench with loading hole facing down on bench.
4. With all ball bearings removed (check by rotating while looking into ball loading hole), pull the two halves apart and discard old rings, ball bearings and seals.
5. Clean and dry swivel thoroughly, install new seal and wear rings when required, and lubricate the female bore and male outside diameter before assembly. Load retainer ball bearings and install grease zerk (a temporary zerk is provided for models with a retaining bolt). Use lithium based grease with moly (do not over grease).

Note: The temporary grease zerk must be removed and replaced with the original retaining bolt and new lock washer on swivels which didn't originally have a permanent grease zerk.

Switch Your Swivel![®]